

CK Plus & CK Premium Surface-Mounted Electric Fan Heaters

Engineer/Architect: _____ **Date:** _____

Job Name/Customer: _____ **Phone:** _____

Location: _____ **Date Required:** _____

Contractor: _____ **Phone:** _____

CK model	Item No.	Quantity	kW	Voltage

Description

Stiebel Eltron CK Plus and CK Premium wall-mounted electric heaters are designed for installation where quick heat is needed. They have an ultra-quiet fan and will replace existing recess-mount heaters. A built-in thermostat has a frost protection setting. The CK Premium adds an interactive full digital display with features like customizable time programs, night mode, open window detection, adaptive start, and a 120-minute booster heater function. CK Premium also features two heating stages, with a nearly-silent low-power economy mode.

Specifications

Model	CK 150-1 Plus	CK 150-1 Premium	CK 200-2 Plus		CK 200-2 Premium	
Item number	202031	202033	202032		202034	
Voltage	120 V	120 V	240 V or 208 V		240 V or 208 V	
Heating output stages	1	2	1		2	
Wattage	1500 W	1500 W / 750 W	2000 W	1500 W	2000 W / 1000 W	1500 W / 750 W
Max. amperage	12.5 A	12.5 A	8.3 A	7.5 A	8.3 A	7.5 A
Rated output Btu/hr	5118	5118 / 2559	6824	5118	6824	5118 / 2559
Air volume	106 CFM	106 CFM	106 CFM		106 CFM	
Recommended circuit breaker size¹	15 A	15 A	15 A		15 A	
Minimum wire size (copper)	14 AWG	14 AWG	14 AWG		14 AWG	
Electrical connection	Power cord with plug, hard-wiring optional	Power cord with plug, hard-wiring optional	Junction box, rear		Junction box, rear	
User interface	Control knob	Illuminated LCD display	Control knob		Illuminated LCD display	
Timer	no	yes	no		yes	
Room size estimate	150 sq.ft.	150 sq.ft.	200 sq.ft.		200 sq.ft.	
Operating noise	48 dB(a)	48 dB(a) / 37 dB(a)	48 dB(a)		48 dB(a) / 37 dB(a)	
Heating element	nichrome wire					
Dimensions	H 18½" (470 mm) x W 13¾" (345 mm) x D 4¼" (126 mm)					
Weight	11.7 lb (5.3 kg)					
Temperature range	41-86 °F (5-30 °C)					
Frost protection setting	45 °F (7 °C)					



¹ This is our recommendation as the manufacturer. Check local codes for compliance if necessary.

rev. 3.2021 Due to our continuous process of engineering and technological advancement, specifications may change without notice.

Dimensions & clearances

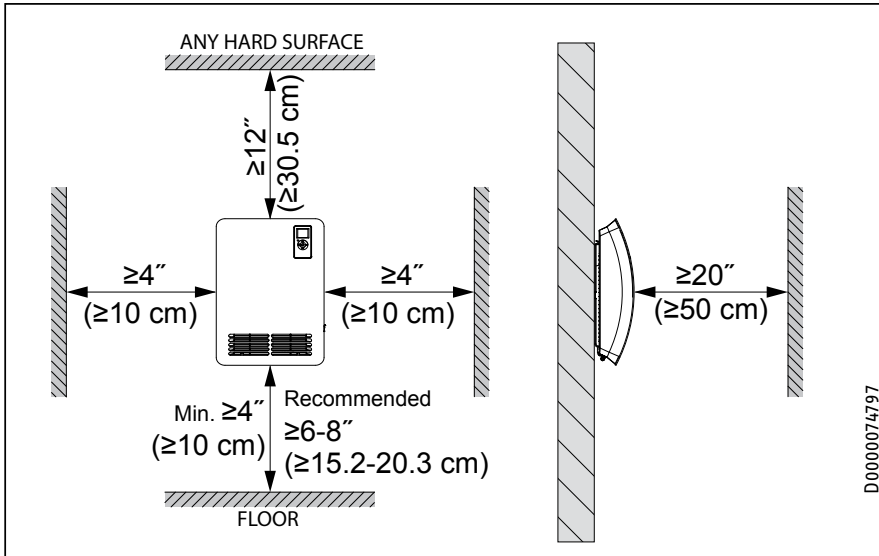

Wiring diagram CK 150-1 Plus, CK 200-2 Plus

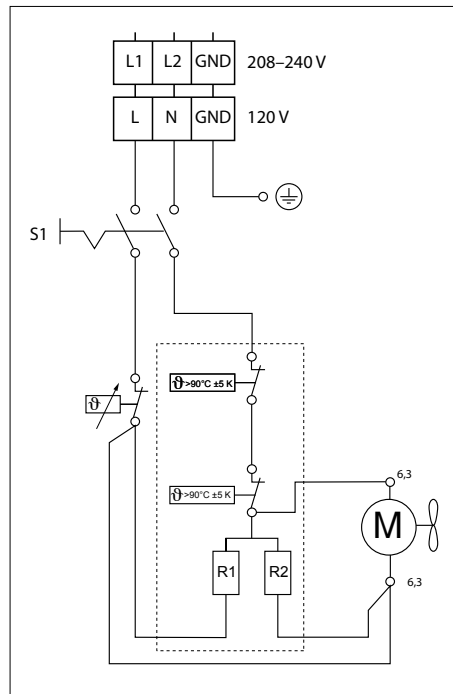

Wiring diagram CK 150-1 Premium, CK 200-2 Premium

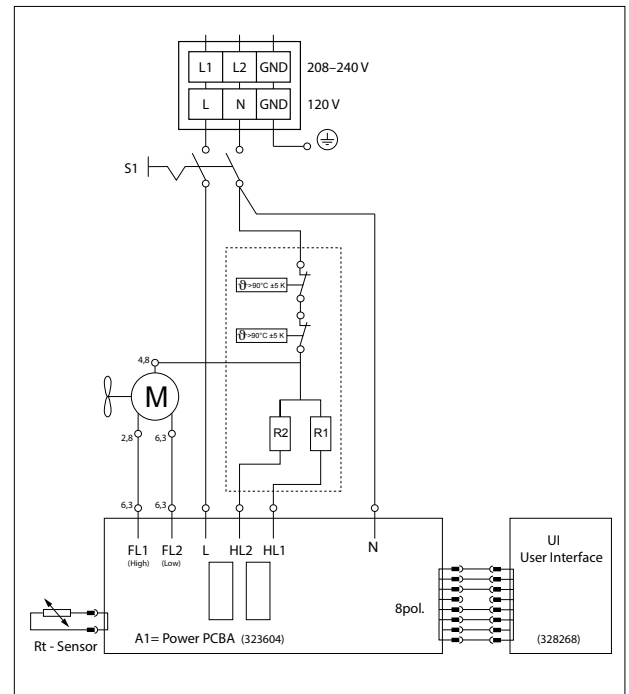

Intertek

Certified to

ANSI/UL Std. 2021

Conforms to

CAN/CSA

Std. 22.2 No. 46

ISO 9001
CERTIFIED

Warranty

Residential & commercial warranty: Stiebel Eltron warrants to the original owner that the CK Plus or CK Premium wall mounted electric fan heater will be free from defects in workmanship and materials for a period of three (3) years from the date of purchase. Should the part(s) prove to be defective under normal use during this period, Stiebel Eltron, Inc. will be responsible for replacement of the defective part(s) only. Stiebel Eltron, Inc. is not responsible for labor charges to remove and/or replace the defective part(s), or any incidental or consequential expenses. Should the owner wish to return the heater for repair, the owner must first secure written authorization from Stiebel Eltron, Inc. The owner shall be required to show proof of purchase date, and to pay all transportation costs to return the defective part(s) or heater for repair or replacement. Warranty is void if heater has been installed or used improperly or if design has been altered in any way. Complete warranty available online.